

## Education

Mar. 2015	Nihon University Fujisawa High School
Mar. 2019	Bachelor of Engineering in Aerospace Engineering, College of Science and Technology, Nihon University
Mar. 2021 (expected)	Master of Engineering in Aerospace Engineering, Graduate School of Science and Technology, Nihon University

## Qualifications

Aug. 2015	CATIA V5 Part Design Specialist CATIA V5 Assembly Design Specialist
Oct. 2016	CATIA V5 Associate - Part Design CATIA V5 Associate - Assembly Design CATIA V5 Mechanical Designer Specialist
Sep. 2019	Amateur Third-Class Radio Operator

## Research

### Research Keywords

SDMT: **Self-Deployable Membrane Truss**, Deployment Dynamics, FEM,  
ALE: **Arbitrary Lagrangian-Eulerian method**, structure engineering

### Oral presentation

S. Kataoka, Y. Miyazaki: Deployment Dynamics of Self-Deployable Membrane Truss, 32nd International Symposium on Space Technology and Science, 2019-c-12, 2019.

### Oral presentations, Papers (co-author)

- 福永桃子, 宮崎康行, 高坂大樹, 片岡星太: 円筒に巻き付けられたコンベックステープの自己伸展運動における非剥離条件, 第62回宇宙科学技術連合講演会講演集, JSASS-2018-4297, 2018.
- T. Nakamura, S. Shitara, S. Kataoka, Y. Miyazaki: Shape Sensitivity Analysis of Starshade Using Self-Deployable Membrane Truss, 32nd International Symposium on Space Technology and Science, 2019-c-13, 2019.
- S. Shitara, S. Kataoka, D. Kawarabayashi, T. Nakamura, Y. Miyazaki: Space Demonstration of Occulter Using Self-Deployable Membrane Truss, IAC-C.2.2.9, 2019.
- S. Shitara, S. Kataoka, A. Kawashita, Y. Miyazaki: Concept Design of Occulter Using Modular Self-Deployable Membrane Truss, AIAA-2020-1182, AIAA Scitech 2020 Forum, 2020.

SDMT: **Self-Deployable Membrane Truss** can be configured by combining such booms and nodes. The truss member is self-extensible boom such as Bi-convex boom. Thus, the truss deploys with no powered actuator and the membrane attached to the truss is deployed, too. The structure has enough stiffness, high storage efficiency and applicability to modular structure.

So SDMT can be applied to large antenna, Starshade and Debris Capture Device.

SDMT deploys by the self-extension force of booms, but if the extension force is different from the design value, the failure occurs during deployment. Accordingly, I take the following measures.

- Design of extension force by adopting the CFRP member
- Formulation of the feeding motion of the boom & Analysis of deployment dynamics
- Design the parts & the mechanisms

The purpose of my research is to solve these points and to complete the basic design of SDMT by conducting experiment under  $\mu G$  and verifying the analysis and mechanism.

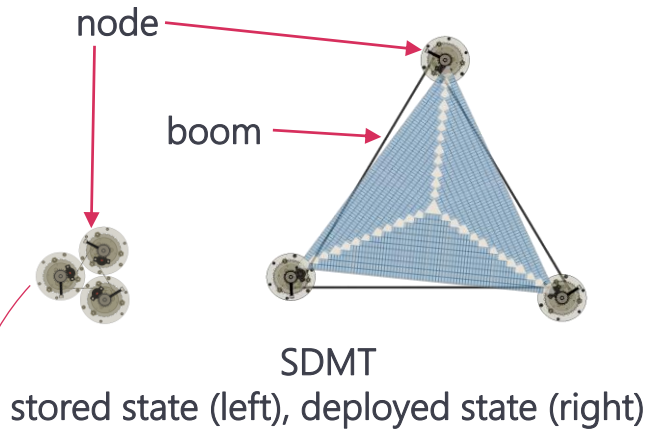

detail of node (conventional)

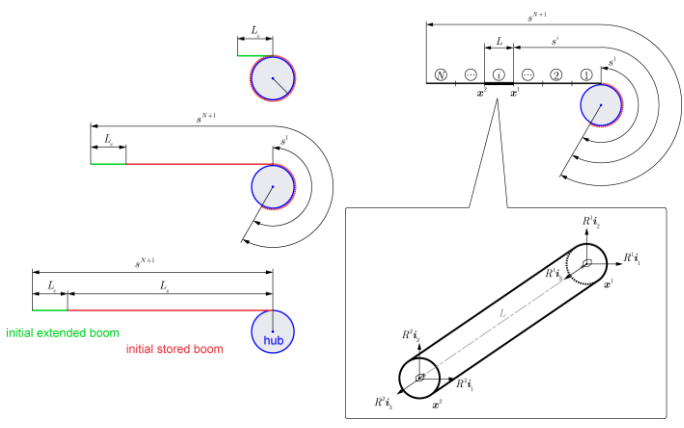

analysis model

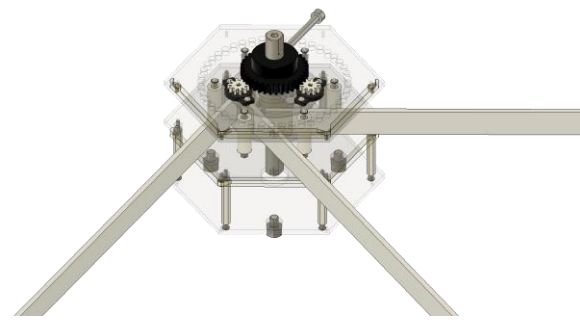

detail of node (novel)